

FASTTRACK

ENGINEERING

DUST COLLECTORS

Fast Track collectors are a balanced range of highly efficient units incorporating fabric filters with automatic sequential reverse jet cleaning, specifically designed as a cost effective solution for most dust control problems.

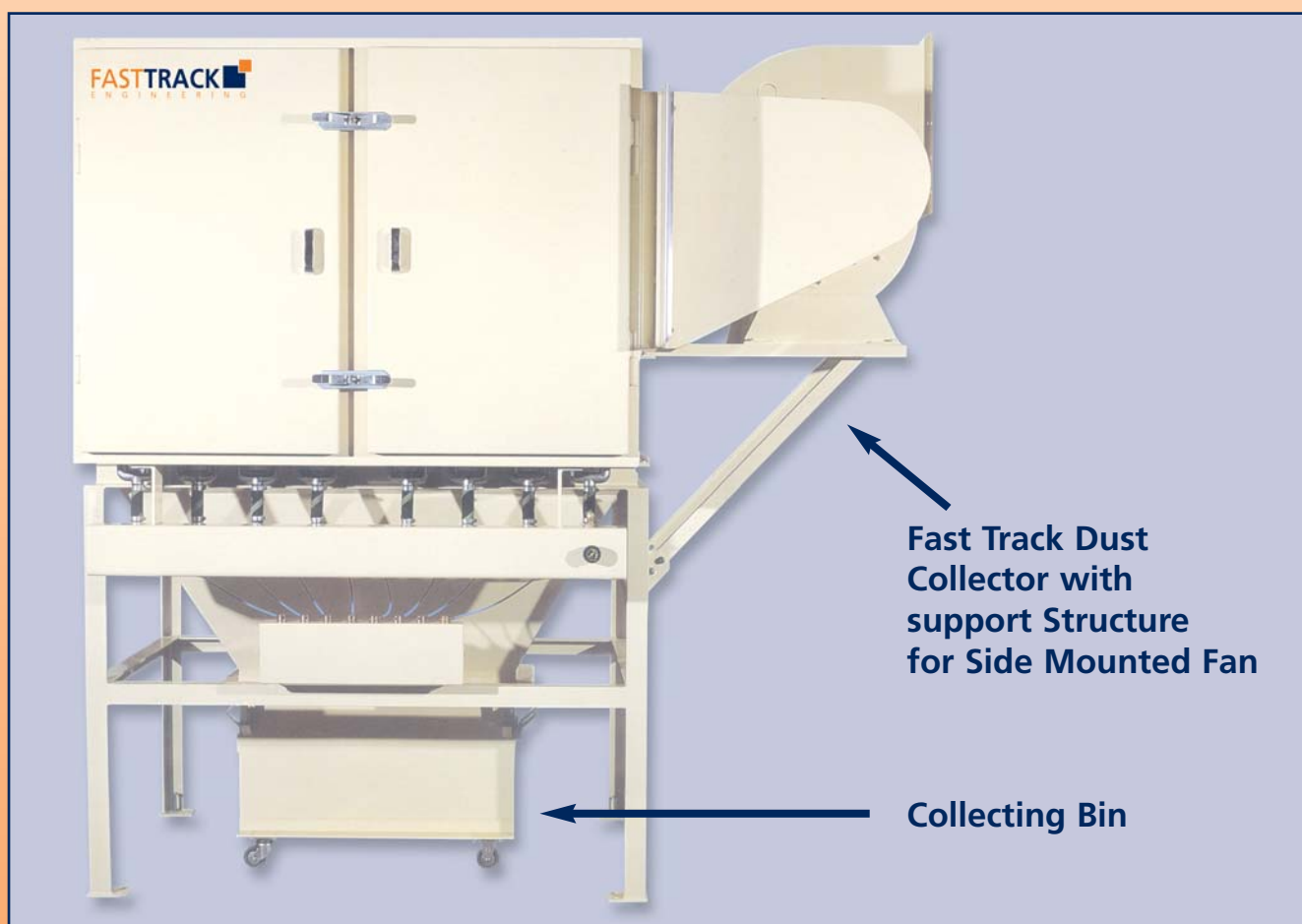

Rotary Valve

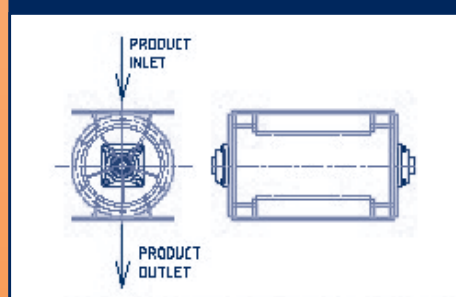

Screw Conveyor for Transportation of Starch & Granulated Products

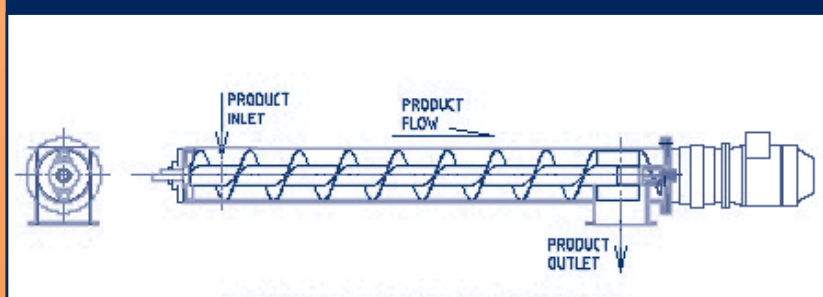

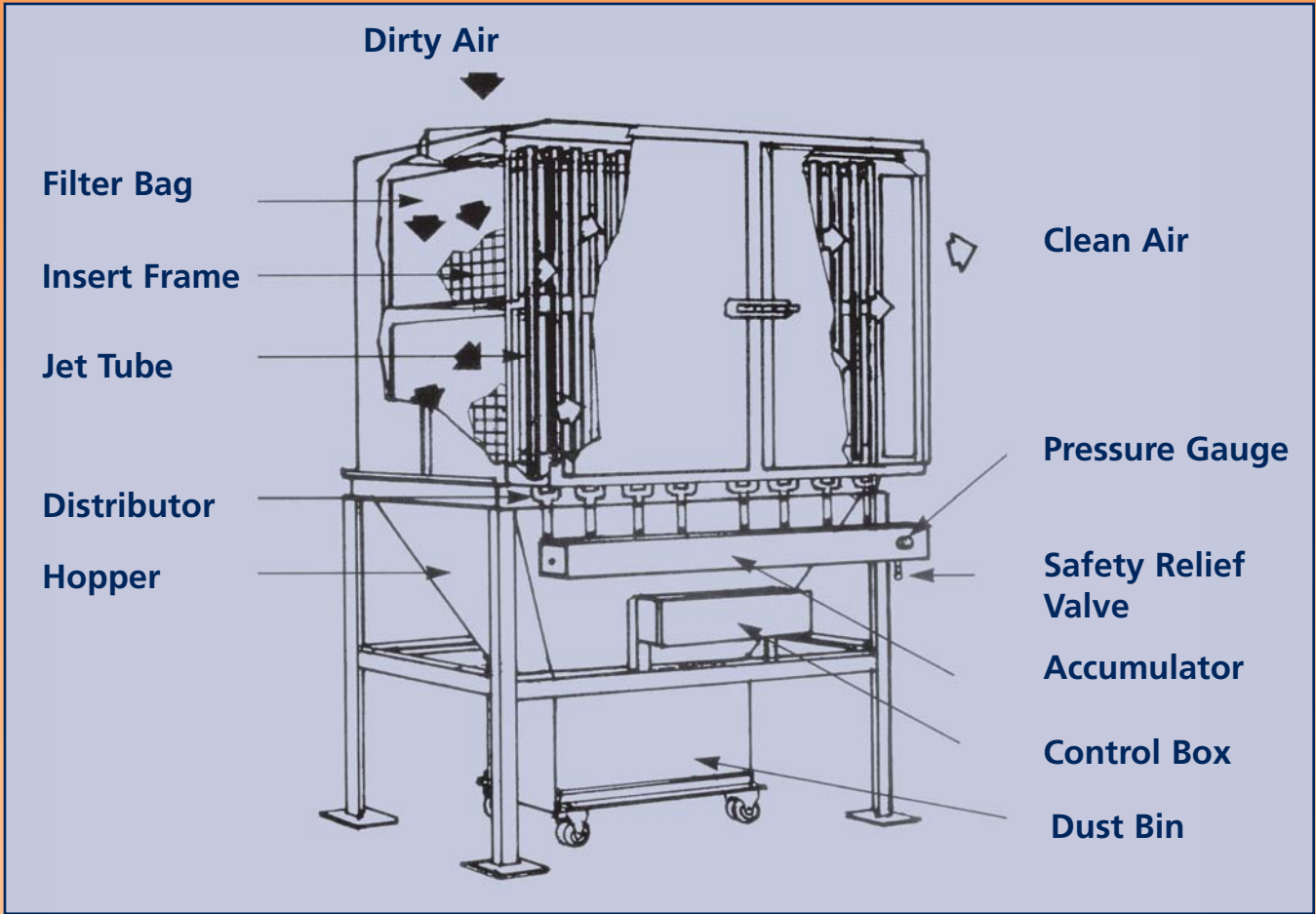

In many if not all industries the extraction of dust became a major issue not to be ignored.

An efficient dust collection and dust removal not only protects the environment, but also improves working conditions whereby people are protected from illness and unwanted accidents.

FASTTRACK
ENGINEERING

Fast Track Engineering Pty Ltd
Engineers that think beyond the square!
p: 61 2 9604 8677 f: 61 2 9604 3622
e: sales@FTEngineering.com.au

104 Redfern St, Wetherill Park NSW 2164, Sydney Australia. ABN 641 0784 5947